

# Lead seals



*Specifications and design are subject to change without any notice or obligation from the manufacturer*

## Specifications

- Lead seal 99,9% purity
- It may be used with different sealing wires. Pliers are required for the correct closure and use
- Diameter size: 8mm, 10mm, 11mm, 12mm, 13mm, 14mm and 16mm
- It can be customised by using the appropriate pliers

Article	Thickness	Qty per kg
PM 8mm	5mm	440
PM 10mm	5mm	315
PM 11mm	5.8mm	255
PM 12mm	5.5mm	230
PM 14mm	6mm	150
PM 16mm	6.3mm	98

## Packaging

### PM 8MM/10MM/12MM/13MM/14MM

- Box with 10kg
- Box size: 24x18x11cm
- Box weight: 10kg
- Pallet: 80x120x81cm, 1000kg, 100 boxes

### PM 16MM

- Box with 20kg
- Box size: 26x26x16 cm
- Box weight: 20 kg
- Pallet: 80x120x95 kg 1200

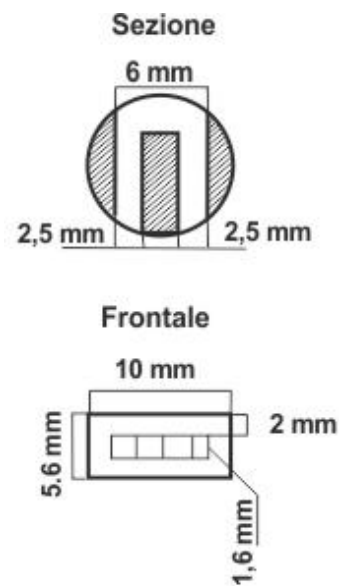

CUSTOMS CODE: 83099090

[info@leghorngroup.com](mailto:info@leghorngroup.com)

Protection - Control - Identification - Tracking - RFID solutions - [www.leghorngroup.com](http://www.leghorngroup.com)

