

Anchorflag

Wire seal



Specifications

- Available in polycarbonate or polypropylene
- To be used with different sealing wires or strings. Any pliers for the correct closure is required.
- Working temperature: -30°C $+60^{\circ}\text{C}$
- Marking: laser
- Progressive numbering up to 15 digits
- Logo and barcode available options
- Customisation up to 20 characters on one line
- Available in transparent colours
- Available colours: orange, blue, white, yellow, red green and purple



- Further colours may be manufactured upon request

Specifications and design are subject to change without any notice or obligation from the manufacturer

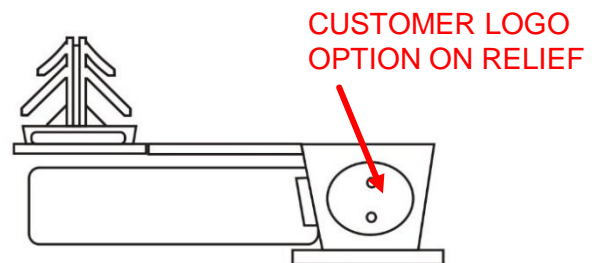
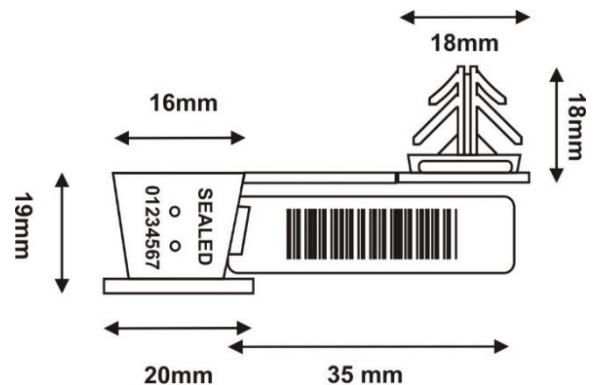

Packaging

- Box with 5000 seals in bags of 100 pcs
- Box size: 60x40x33cm
- Box weight: 14,5 kg
- Pallet: 100x120x150cm, 310 kg, 100000 pcs

CUSTOMS CODE: 39269097

info@leghorngroup.com

Protection - Control - Identification - Tracking - RFID solutions - www.leghorngroup.com

